

FG

**Gas Filters
DN15 ... DN300**

FG

Gas Filters

Contents

| | |
|--------------------------------------|---|
| Description | 2 |
| Features | 2 |
| Functioning and application | 3 |
| Technical specifications | 4 |
| Gas flow chart (pressure drop) | 6 |
| Ordering information | 8 |
| Accessories and optionals | 8 |
| Standards and approvals | 9 |

Description

The FG type is a filter for gas pipelines according to DIN 3386, with very high holding capacity of dust and impurities, suitable for the protections of devices installed downstream.

Features

The filters are made of aluminum alloy die-cast, with a wide range for inlet/outlet connections from DN15 up to DN 300.

Suitable for natural gas, town gas, LPG (gaseous) and air. On request the filters can be provided with special seals suitable for aggressive gases.

The incorporated filtering cartridge is a steel support frame covered with a double-layer high performance nonwoven made of polyolefine fibers, which satisfy the stringent requirements of Fire Class F1 according to DIN 53438 and are thus self-extinguishing.

Considering the same connection, the FGS are smaller models of FG filters: the body is more compact with a reduced filtering surface.

FGS1-FGS2 models are provided with a mesh filter cartridge.

FG98-FG910-FG912 models are provided with a 2-stage single-layer filtering cartridge.

Provided with pressure gauges for both inlet and outlet chamber (optional for threaded models).

All components are designed to withstand any mechanical, chemical and thermal condition occurring during typical service. Effective impregnation and surface treatments have been used to improve mechanical sturdiness, sealing and resistance to corrosion of the components.

Filters are 100% tested by computerized testing machineries and are fully warranted.

Functioning and application

The FG type filter is designed for installation in gas lines and compressed air lines, to protect downstream fittings.

The filtering cartridge made of nonwoven polypropylene fibers with a metal support frame, is suitable to retain dust and other impurities with size $\geq 30\mu\text{m}$.

When the dust storage capacity is exceeded or if there is an excessive pressure difference, the filter loses its protective function. In this case the filter element must be replaced.

FGS1-FGS2 models are provided with a mesh filter cartridge ($50\mu\text{m}$), which is easy washable.

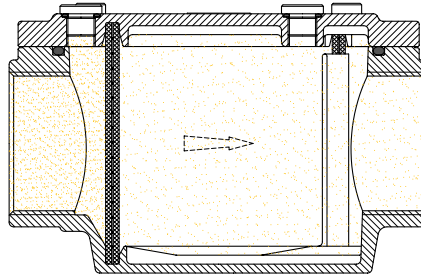

Fig.1

Figure 2 shows an example of installation.

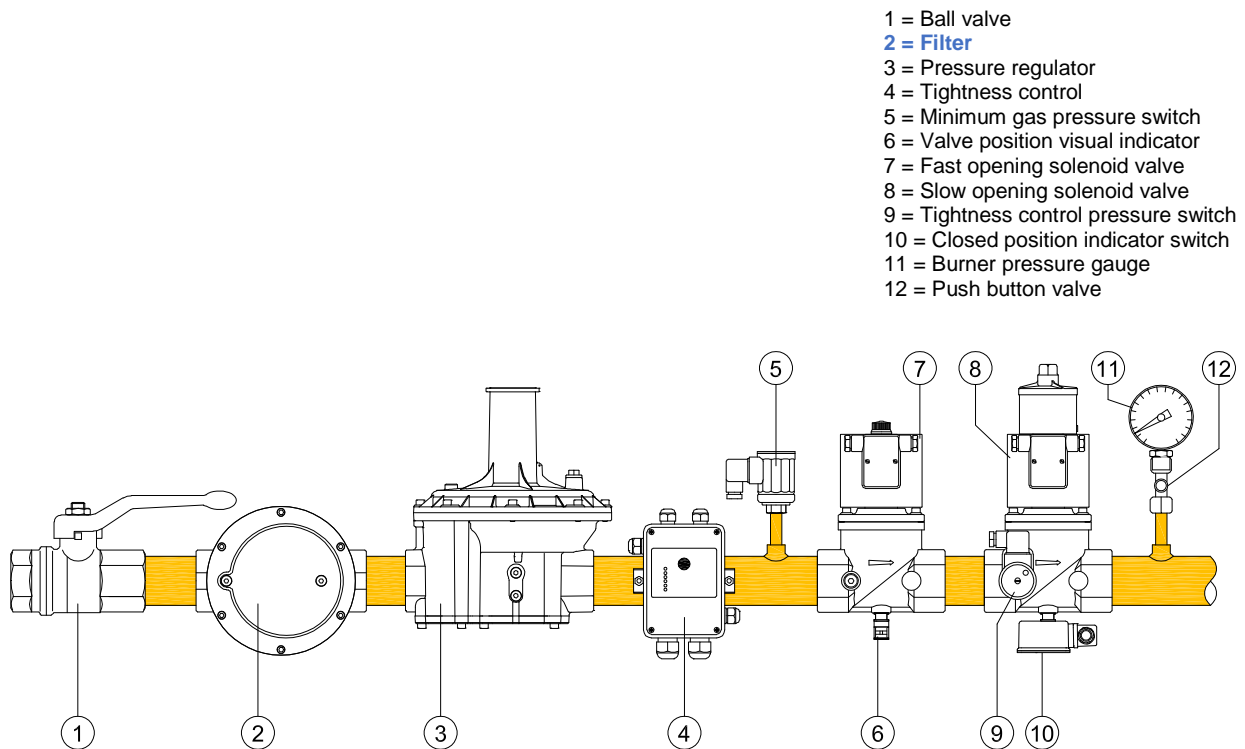

Fig.2

Technical specifications

Tab. 1

| | |
|--|---|
| Connections | Gas threaded ISO 7-1 from Rp1/2 to Rp2 or ANSI-ASME B1.20 from 1/2"NPT to 2"NPT Flanged PN16 – ISO 7005 from DN65 to DN300 or ANSI-ASA-ASME B16.5 class 150 from 2" to 10" |
| Max. operating pressure | 2 bar (30 psig) 6 bar* (90 psig) |
| Body test pressure | 3 bar (45 psig) 9 bar* (130 psig) |
| Ambient temperature Media temperature | -40°C / +80°C (-40°F to +176°F) |
| Flow capacity | see charts |
| Pore width of filter element | ≤ 50 µm (mesh filter cartridge FGS1, FGS2) ≤ 30 µm (double-layer polypropylene cartridge) ≤ 5 µm (optional - polypropylene cartridge) |
| Filtration class | G4 according to EN 779 |
| Pressure gauges (when provided) | Inlet and outlet chambers 1/8" onto threaded models (except FGS1-FGS2) 1/4" onto flanged models |
| Installation | Into horizontal and vertical pipeline |
| Gas type | Natural gas, town gas, LPG (gaseous) of families 1,2,3 biologically produced methane and air On request special version for aggressive gases |

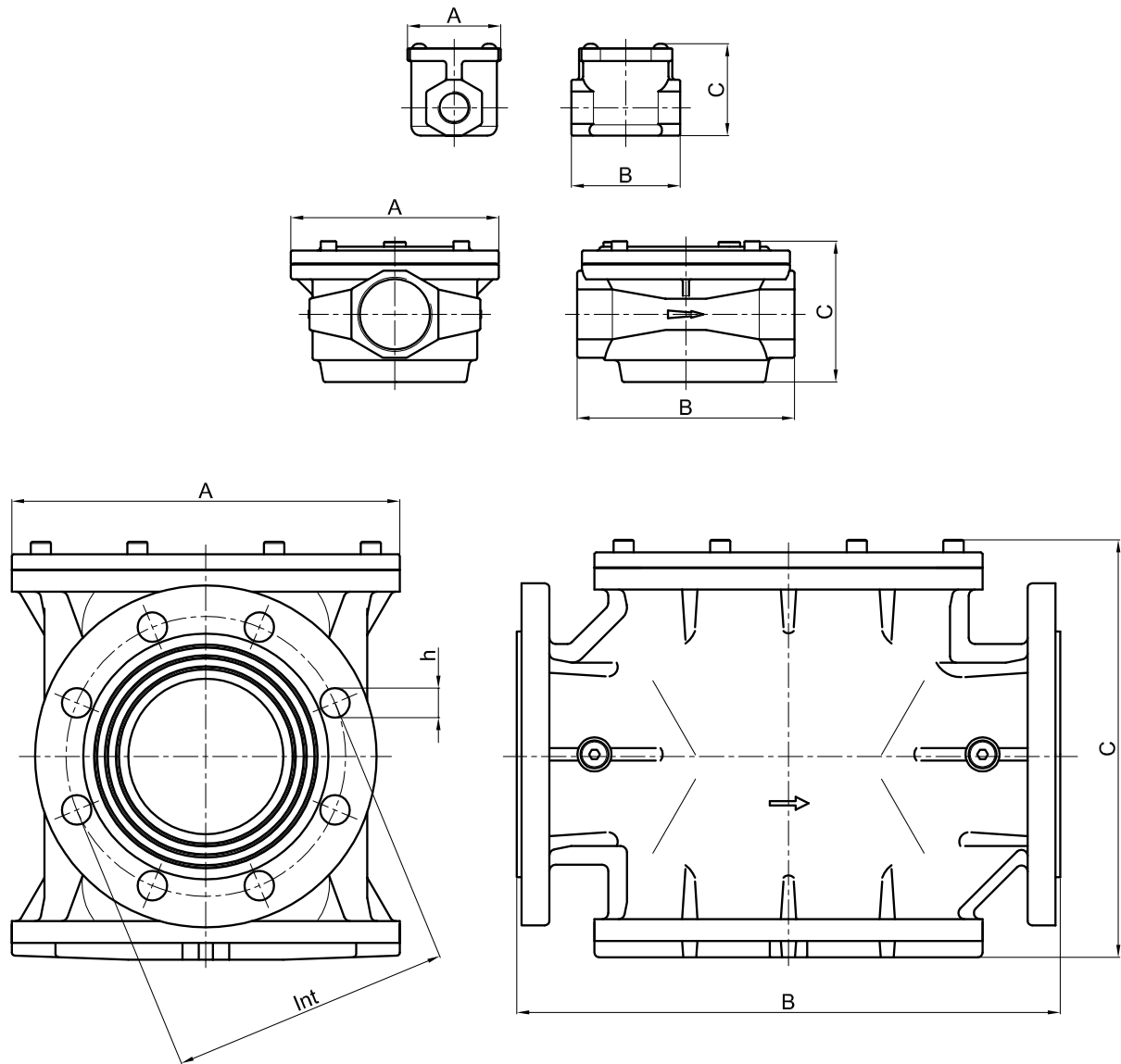

Fig.3

Tab. 2

| Model | Connection | Flow factor Kvs [m ³ /h] | Overall dimensions [mm] | | | | | Weight [Kg] | Filtering area [cm ²] |
|--------------------|------------|---|----------------------------|-----|-----|-----|-------|----------------|---|
| | | | A | B | C | Int | h | | |
| FGS1 | Rp 1/2 | 6,8 | 60 | 70 | 60 | | | 0,24 | 17 |
| FGS2 | Rp 3/4 | 11 | 60 | 70 | 60 | | | 0,22 | 17 |
| FG1 | Rp 1/2 | 6,8 | 88 | 96 | 84 | | | 0,39 | 55 |
| FG2 | Rp 3/4 | 11 | 88 | 96 | 84 | | | 0,38 | 55 |
| FGS3 | Rp 1 | 16 | 88 | 96 | 84 | | | 0,36 | 55 |
| FG3 | Rp 1 | 22 | 134 | 140 | 91 | | | 0,97 | 145 |
| FG35 | Rp 1 1/4 | 26 | 134 | 140 | 91 | | | 0,91 | 145 |
| FGS4 | Rp 1 1/2 | 30 | 134 | 140 | 91 | | | 0,85 | 145 |
| FG4 | Rp 1 1/2 | 50 | 182 | 208 | 128 | | | 2,2 | 330 |
| FG6 | Rp 2 | 70 | 182 | 208 | 128 | | | 2,0 | 330 |
| FG4 ⁽¹⁾ | DN 40 | 50 | 182 | 260 | 165 | 110 | 4x18 | 3,6 | 330 |
| FG6 ⁽¹⁾ | DN 50 | 70 | 182 | 260 | 165 | 125 | 4x18 | 3,8 | 330 |
| FG7 | DN 65 | 110 | 200 | 308 | 212 | 145 | 4x18 | 8,5 | 535 |
| FG8 | DN 80 | 150 | 200 | 308 | 212 | 160 | 8x18 | 8,4 | 535 |
| FG9 | DN 100 | 200 | 250 | 350 | 265 | 180 | 8x18 | 13,5 | 860 |
| FG93 | DN 125 | 350 | 315 | 460 | 347 | 210 | 8x18 | 22,8 | 1540 |
| FG95 | DN 150 | 450 | 315 | 460 | 347 | 240 | 8x23 | 24,5 | 1540 |
| FG98 | DN 200 | 460 | 370 | 546 | 420 | 295 | 12x23 | 47 | 2760 ⁽²⁾ |
| FG910 | DN 250 | 550 | 405 | 600 | 466 | 355 | 12x28 | 69 | 3100 ⁽²⁾ |
| FG912 | DN 300 | 820 | 460 | 700 | 537 | 410 | 12x28 | 96 | 4200 ⁽²⁾ |

(1) flanged kit (2) filtering area is the sum of the two stages

Gas flow chart

(Pressure drop)

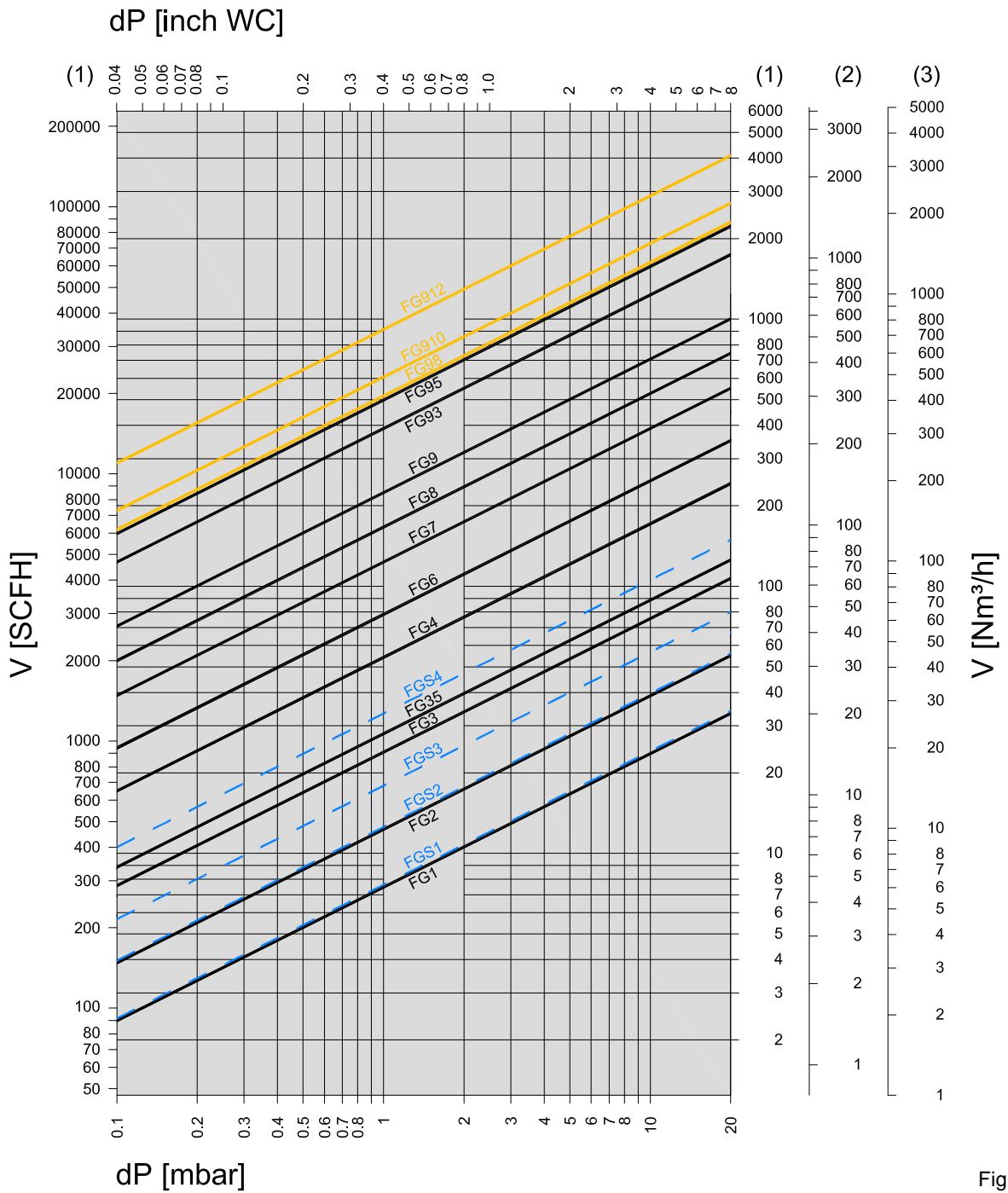

Fig. 4

**Formula of conversion
from air to other gases**

$$V_{GAS} = k \cdot V_{AIR}$$

Tab. 3

| Gas type | Specific gravity ρ [Kg/m³] | $k = \sqrt{\frac{1,25}{\rho_{GAS}}}$ |
|-----------------|---------------------------------------|--------------------------------------|
| (1) Natural gas | 0,80 | 1,25 |
| (2) LPG | 2,08 | 0,77 |
| (3) Air | 1,25 | 1,00 |

15°C, 1013 mbar, dry

When the flow read on the diagram is referred to operating pressure instead of standard conditions, the pressure drop Δp read on the diagram must be multiplied for the factor (1+ relative pressure in bar):

Example:

In the 2" filter with an air flow of 100 Nm³/h there is a pressure drop $\Delta p = 4$ mbar. If we consider that 100 m³/h is the flow at 2 bar of inlet pressure, then the pressure drop to be consider is:

$$\Delta p = 4 \times (1 + 2) = 12 \text{ mbar}$$



Filter must be selected considering the following:

- Pressure drops $\Delta p \leq 10$ mbar
- Flow velocities $w \leq 20$ m/s

Normally, pressure drop and flow rate for the filters are read from the gas flow diagram. However, the filters can also be chosen in accordance with the characteristic "Kvs value" which is shown in table 2.

The selection of the filter requires the calculation of the Kv under the operating conditions.

Considering only subcritical pressure drops:

$$\Delta p < \frac{p_1}{2}$$

Kv can be calculated with the formula:

$$Kv = \frac{V}{514} \sqrt{\frac{\rho(t + 273)}{\Delta p \cdot p_2}}$$

where

- V = flow rate [Nm³/h]
- Kv = flow factor [m³/h]
- ρ = density [Kg/m³]
- p₁ = absolute inlet pressure [bar]
- p₂ = absolute outlet pressure [bar]
- Δp = differential pressure p₁-p₂ [bar]
- t = media temperature [°C]

To the Kv value calculated from operating conditions we add an allowance of 20%, to obtain the minimum Kvs value which the filter should have:

Kvs > 1,2 Kv

Example:

We need a filter with a capacity of 100 Nm³/h of air at 15°C, with an inlet pressure p₁ = 2 bar. Considering a pressure drop $\Delta p_{max} = 10$ mbar, we obtain:

$$Kv = \frac{100}{514} \sqrt{\frac{1,25(15 + 273)}{0,010 \cdot (1 + 2)}} = 21,3 \text{ m}^3 / \text{h}$$

The filter with Kvs > (1,2 x 21,3) = 25,5 m³/h is the DN40, which has Kvs=40 m³/h (table 2). The diagram shows that in a DN40 filter with 100 Nm³/h of air there is a pressure drop:

$$\Delta p = 7,8 \text{ mbar}$$

Ordering information

Tab.4

| | | | | | | | | | |
|--------------------------------|--|------------|-----|-----------|----------|----------|----------|-----------|--|
| | | | | FG | 2 | 2 | A | .J | |
| Filter type | | | | | | | | | |
| Size | | | | | | | | | |
| S1 | 1/2" small | | | | | | | | |
| S2 | 3/4" small | | | | | | | | |
| S3 | 1" small | | | | | | | | |
| S4 | 1 1/2" small | | | | | | | | |
| 1 | 1/2" | 8 | 3" | | | | | | |
| 2 | 3/4" | 9 | 4" | | | | | | |
| 3 | 1" | 93 | 5" | | | | | | |
| 35 | 1 1/4" | 95 | 6" | | | | | | |
| 4 | 1 1/2" ⁽¹⁾ | 98 | 8" | | | | | | |
| 6 | 2" ⁽¹⁾ | 910 | 10" | | | | | | |
| 7 | 2 1/2" | 912 | 12" | | | | | | |
| Max. Operating pressure | | | | | | | | | |
| 2 | 2 bar (30 psig) | | | | | | | | |
| 6 | 6 bar (90 psig) | | | | | | | | |
| Connection | | | | | | | | | |
| none | Rp internal thread / ISO flange | | | | | | | | |
| A | Rp internal thread / ISO flange with pressure gauges | | | | | | | | |
| N | NPT internal thread / ANSI flange | | | | | | | | |
| NA | NPT internal thread / ANSI flange with pressure gauges | | | | | | | | |
| Special versions | | | | | | | | | |
| J | special seals for aggressive gases | | | | | | | | |
| K | special seals with metal cartridge | | | | | | | | |
| M | 5 µm cartridge | | | | | | | | |
| + | FGS1-2 with nonwoven cartridge | | | | | | | | |

⁽¹⁾ Flanged connections with optional kit

Accessories and optionals

Inlet and outlet pressure chambers can be provided with pressure gauges, to connect a gas differential pressure switch to monitor the pressure difference.

On request a test point fitting can be provided (mounting in charge of the user).

The threaded models 1 1/2" and 2" can be provided with flanged connections using an optional kit.

Standards and approvals

The product complies with the essential requirements of the following European Directives and their amendments:



2014/68/EU (Pressure Equipment Directive)
2011/65/EU (RoHS II)

CE-Reg.-No. PED/0497/2875/14



The product complies with the Technical Regulation RT UD 032/2013 of Russia, Belarus and Kazakhstan.

Certificate No.: CN № RU Д-IT.PA01.B.40716

Quality Management System is certified according to UNI EN ISO 9001.



The information in this document contains general descriptions of technical options available and based on current specifications.

The company reserves the right to make changes in specifications and models as design improvements are introduced, without prior notice.

Elektrogas is a brand name of:

Elettromeccanica Delta S.p.A.
Via Trieste 132
31030 Arcade (TV) – ITALY

tel +39 0422 874068
fax +39 0422 874048
www.delta-elektrogas.com
info@delta-elektrogas.com

Copyright © 2016
All rights reserved