

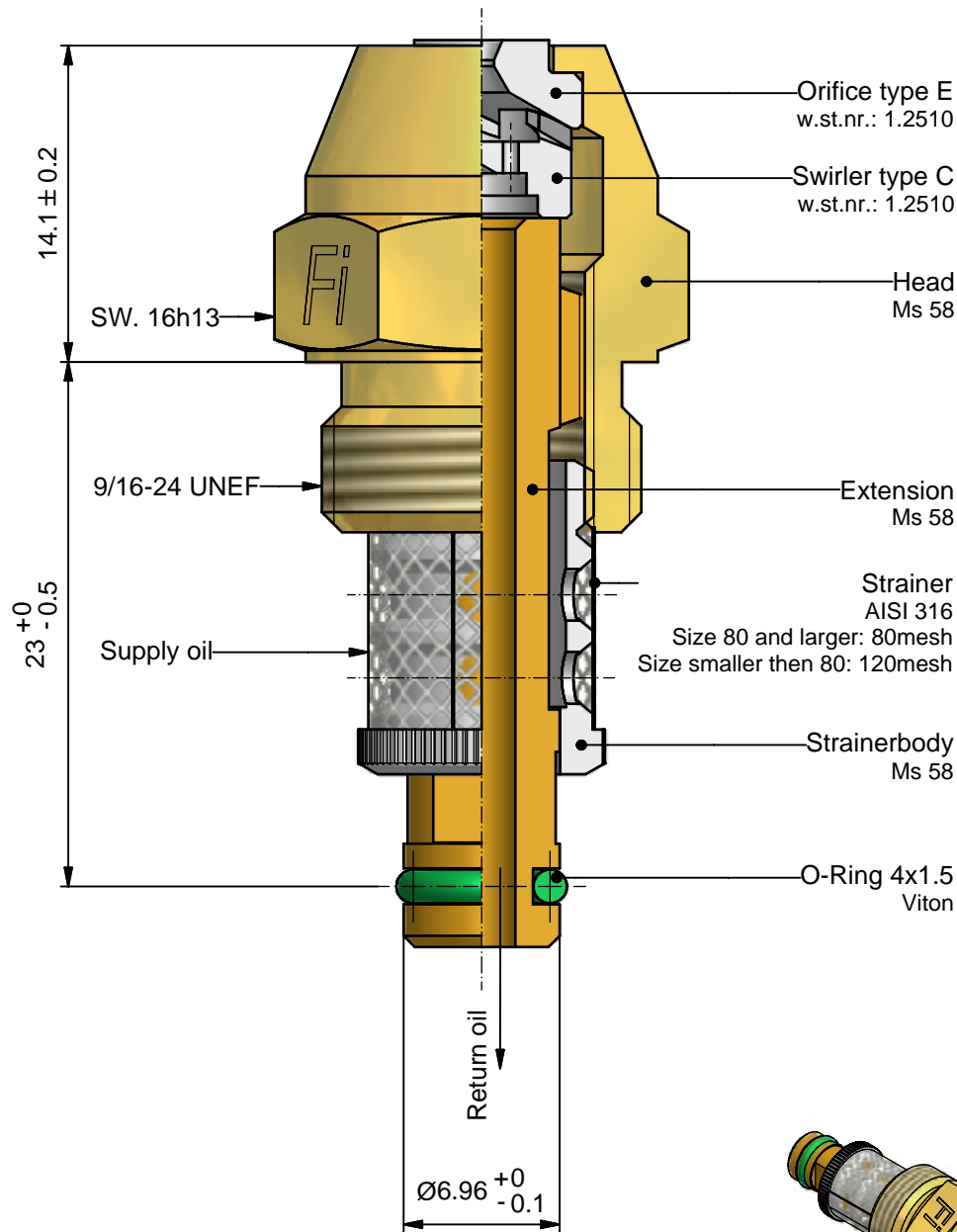

Atomizer 9
KF2-"Size"-45°

09-H1F1-4G-E

20-04-2007



Size [kg/h]
8
10
13
16
20
25
30
35
40
45
50
60
70
80
90
100
115
130
145
160
180
200
225
250
275
300

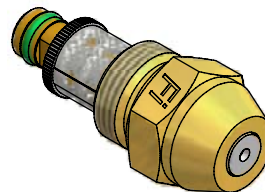

ORDERING: please specify:

- Atomizer type
- Size
- Spray angle
- Quantity

Marking on Hexagon:

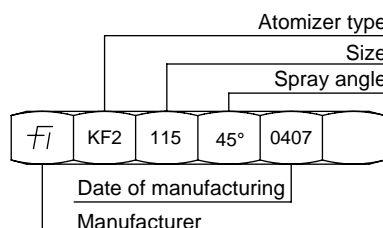

GENERAL DATA:

Test oil viscosity: 5 cSt.
 Supply pressure: 20 bar.
 Max. output with closed return line.
 Turn down 1:4 at return pressure 3 bar.
 Max. output: up to 25 0% +8%
 up to 100 0% +6%
 over 100 0% +5%
 Spray angle: Max. output 45° +1° +6°
 Turned down 60° +0° +6°