

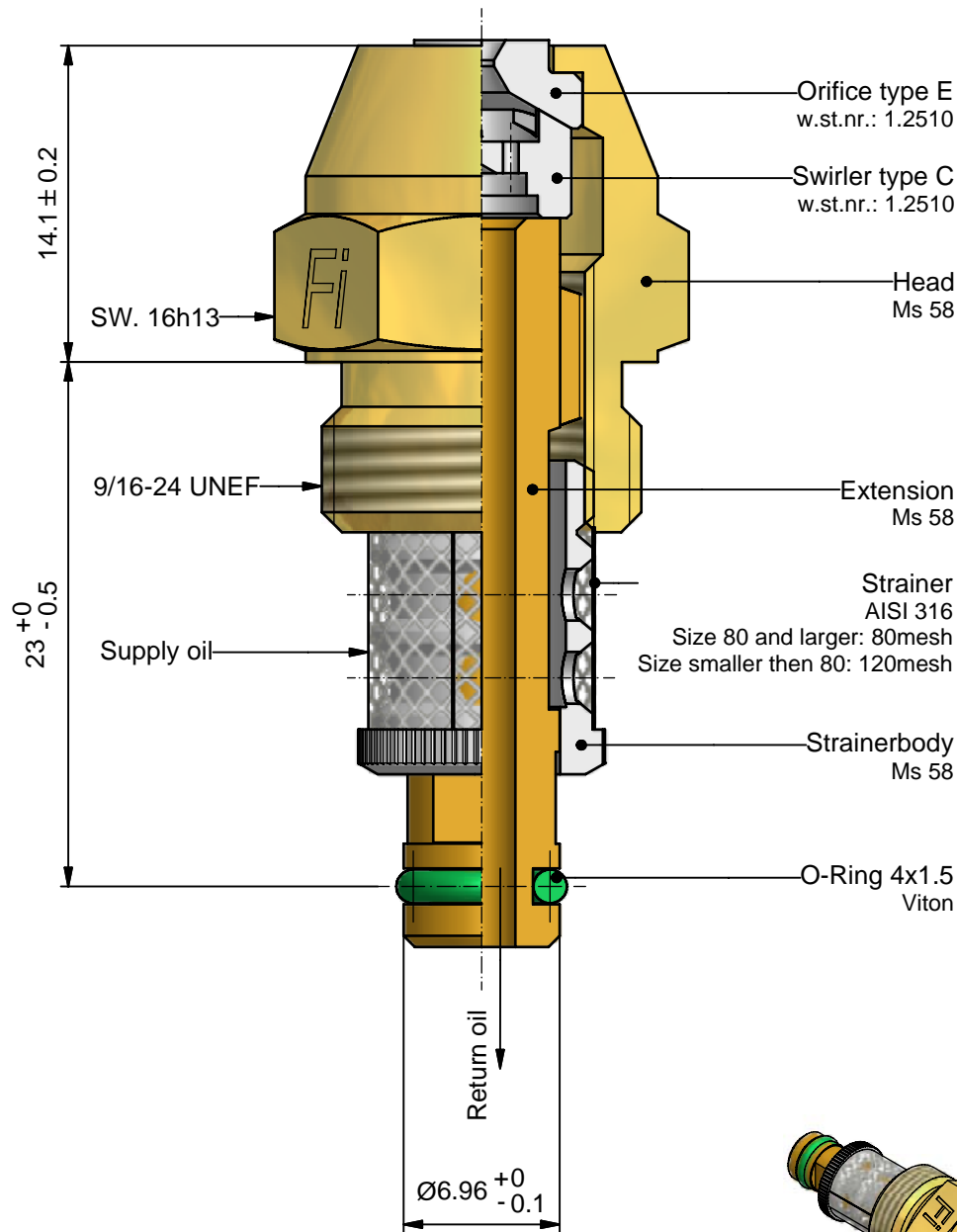

Atomizer 9  
KF2-"Size"-60°

09-H1L1-4G-E

20-04-2007



Size [kg/h]
8
10
13
16
20
25
30
35
40
45
50
60
70
80
90
100
115
130
145
160
180
200
225
250
275
300

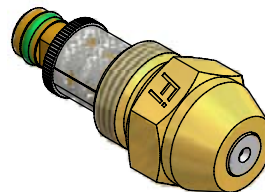

**ORDERING:** please specify:

- Atomizer type
- Size
- Spray angle
- Quantity

**Marking on Hexagon:**

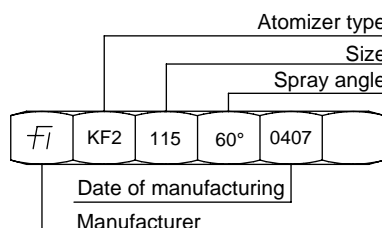

**GENERAL DATA:**

Test oil viscosity: 5 cSt.  
 Supply pressure: 20 bar.  
 Max. output with closed return line.  
 Turn down 1:4 at return pressure 3 bar.  
 Max. output: up to 25 0% +8%  
                   up to 100 0% +6%  
                   over 100 0% +5%  
 Spray angle: Max. output 60° -1° +4°  
                   Turned down 66° +0° +6°