

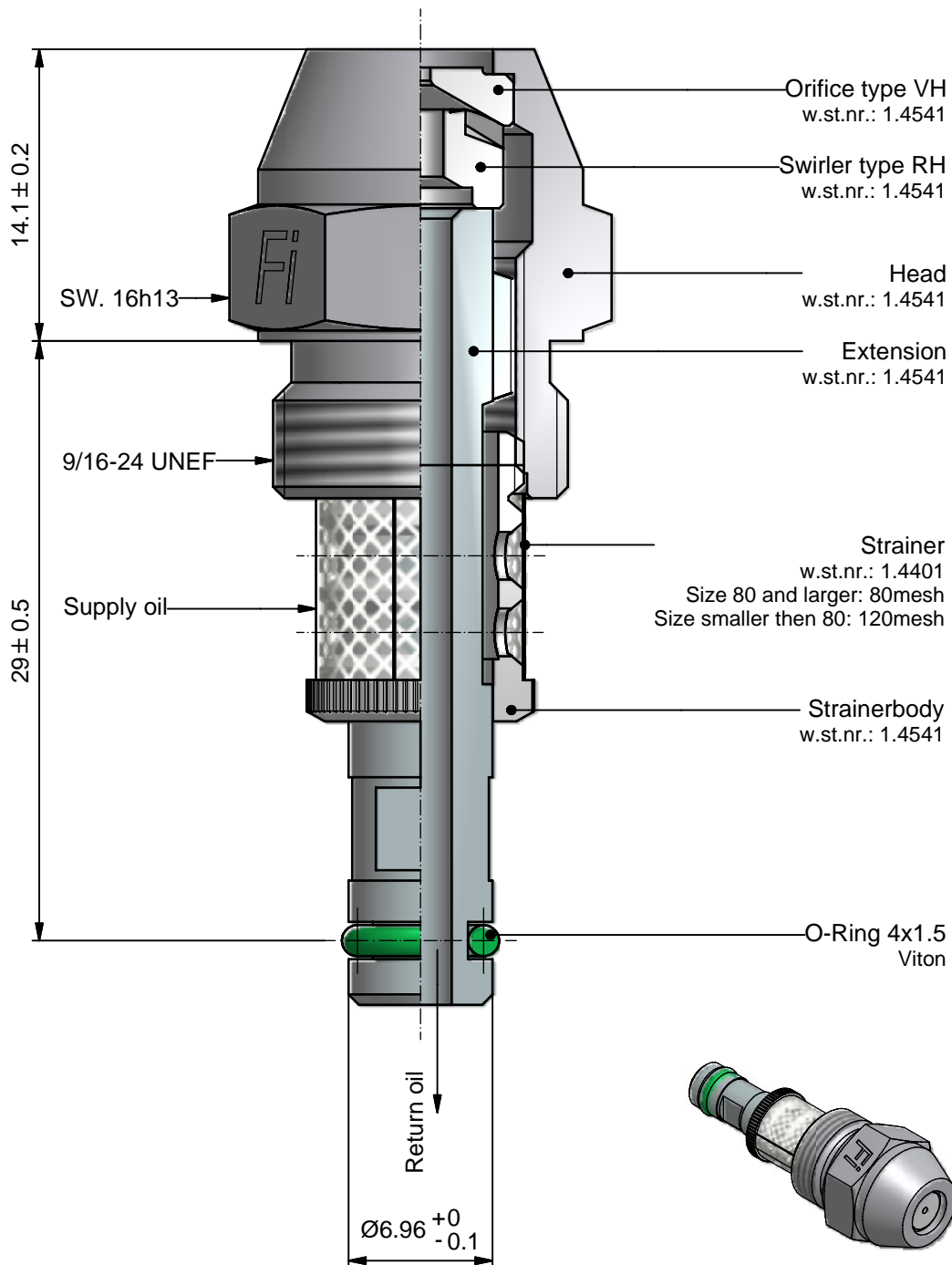

Atomizer 9
KWH3-"Size"-50°

09-J6GQ-4G-E

08-10-2008



Size	[kg/h]
8	
10	
13	
16	
20	
25	
30	
35	
40	
45	
50	
60	
70	
80	
90	
100	
115	
130	
145	
160	
180	
200	
225	
250	
275	
300	

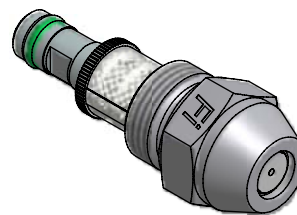

ORDERING: please specify:

- Atomizer type
- Size
- Spray angle
- Quantity

Marking on Hexagon:

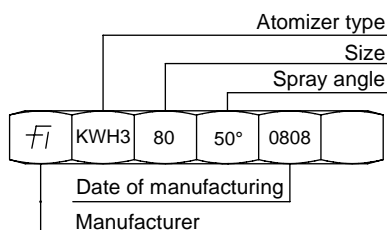

GENERAL DATA:

Test oil viscosity: 5 cSt.
 Supply pressure: 20 bar.
 Max. output with closed return line.
 Turn down 1:3 at return pressure 5 bar.
 Max. output: 0% +5%
 Spray angle: Max. output 50° +5°
 Turned down 70° +8°