

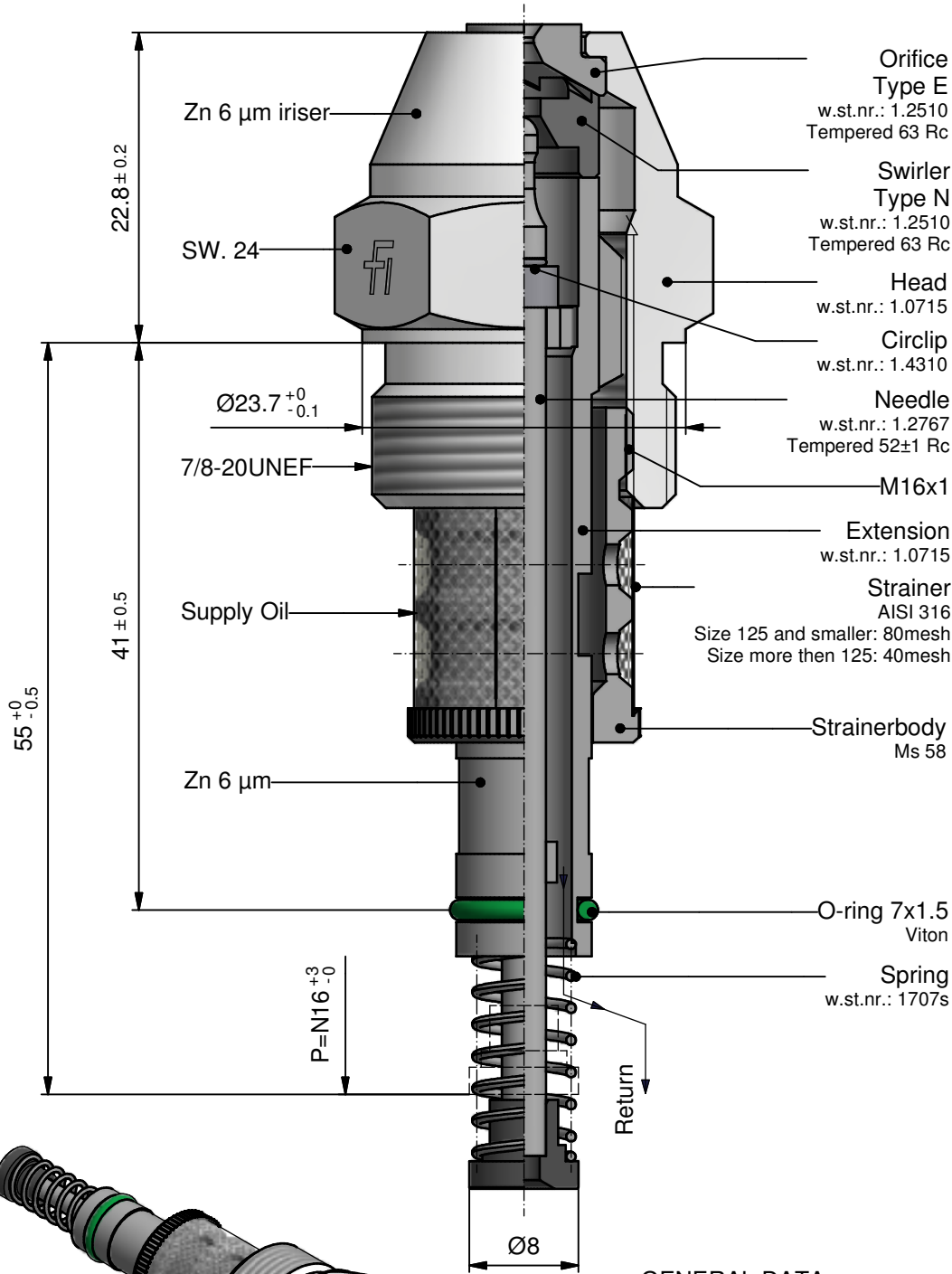

Atomizer 12  
W2 - "Size" - 50°

12-E1GM-4G-E

19-09-18



Size	[kg/h]
20	
25	
32	
40	
50	
60	
70	
80	
90	
100	
115	
130	
145	
160	
180	
200	
225	
250	
275	
300	
330	
360	
400	
450	
500	
550	
600	
650	
700	
750	
800	

GENERAL DATA:

Test oil viscosity: 5 cSt.

Supply pressure: 25 Bar.

Max. output with closed return line.

Turn down 1:4 up to 100 at 10 bar return pressure,  
over 100 at 8 bar return pressure.

Max. output	up to 80	0% +10%
	up to 180	0% +7%
	over 180	0% +5%

Spray angle: Max. output 50° +5°  
Turned down 68° +10°

ORDERING: please specify:

- Atomizer type
- Size
- Spray angle
- Quantity

Marking on Hexagon:

