

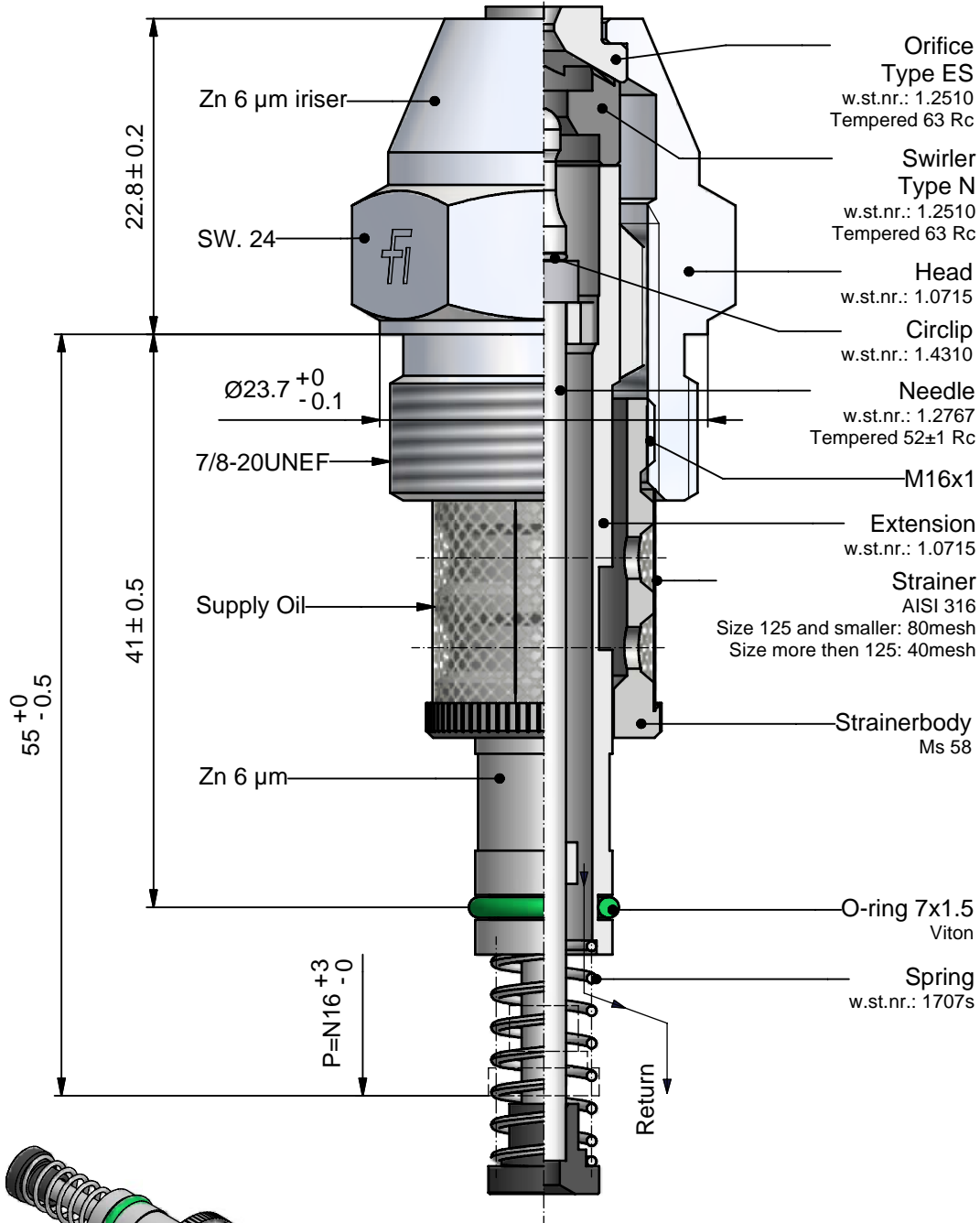

Atomizer 12  
W8 - "Size" - 45° - ES

12-EPF1-4G-E

02-03-2007



Size [kg/h]
40
50
60
70
80
90
100
115
130
145
160
180
200
225
250
275
300
330
360
400
450
500
550
600
650
700
750

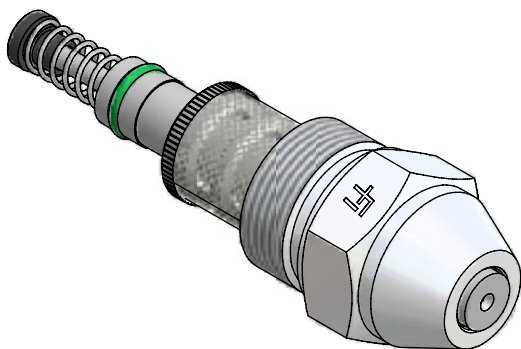

**GENERAL DATA:**

Test oil viscosity: 5 cSt.

Supply pressure: 25 Bar.

Max. output with closed return line.

Turn down 1:8 at 7 bar return pressure.

Max. output	up to 80	0% +10%
	up to 180	0% +7%
	over 180	0% +5%

Spray angle: Max. output 45° +5°  
Turned down 70° +10°

Marking on Hexagon:

Atomizer type

Size

Spray angle

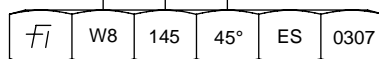

Date of manufacturing

Manufacturer

ORDERING: please specify:

- Atomizer type
- Size
- Spray angle
- Quantity