

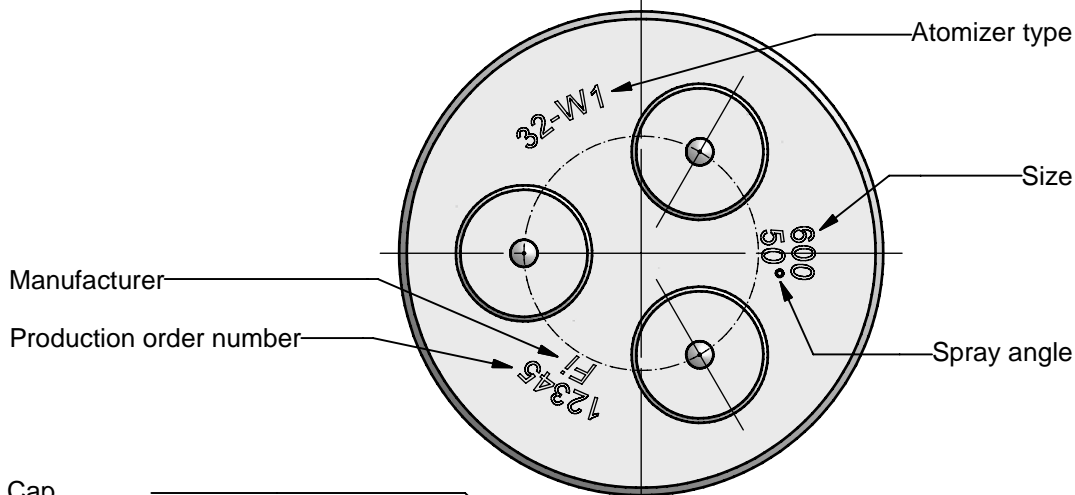

Triplet atomizer
32-W1-"Size"-50°

32-DSGM-4G-E

03-04-2006



Size [kg/h]
60
75
96
120
150
180
210
240
270
300
336
375
420
480
540
600
675
750
825
900
990
1080
1200
1350
1500
1650
1800
1950
2100

- Cap
w.st.nr.: 1.4122
- Orifice
Type L
w.st.nr.: 1.2510
Tempered 63 Rc
- Swirler
Type N
w.st.nr.: 1.2510
Tempered 63 Rc
- Self locking nut
w.st.nr.: 1.0715
Zn 6 µm
- Circlip
w.st.nr.: 1.4310
- Support
w.st.nr.: 1.4122
- Needle
w.st.nr.: 1.2767
Tempered 52 Rc
- Spring
w.st.nr.: 1707s
- Needle holder
w.st.nr.: 1.4122
- Retaining washer
w.st.nr.: 1.4122

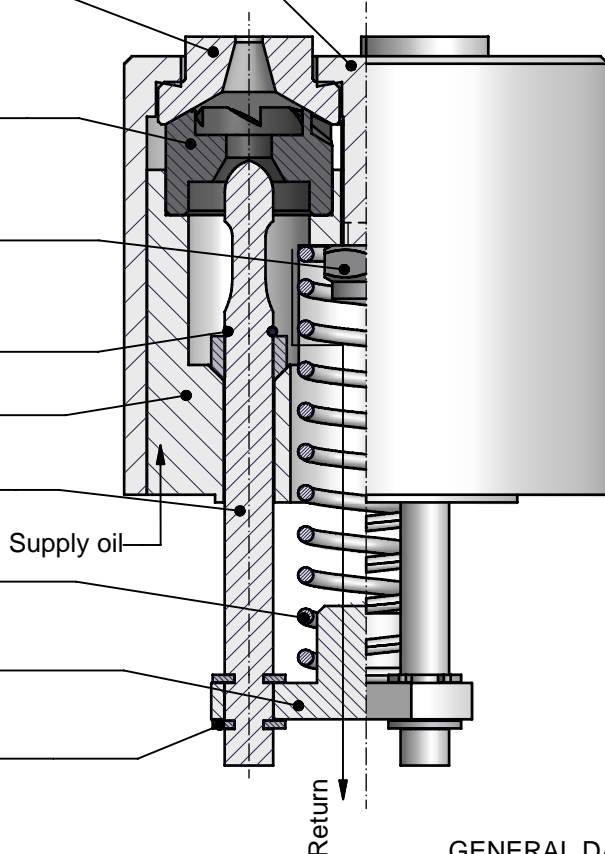

GENERAL DATA:

Test oil viscosity: 5 cSt.
Supply pressure: 20 Bar.

Max. output with closed returnline.

Turn down 1:4 up to 180 at 10 bar return pressure,
over 180 at 7 bar return pressure.

Max. output	up to 240	0% +10%
	up to 540	0% +7%
	over 540	0% +5%

Spray angle: Max. output 50°+5°
Turned down 80°+10°

ORDERING please specify:

- Atomizer type
- Size
- Spray angle
- Quantity

