

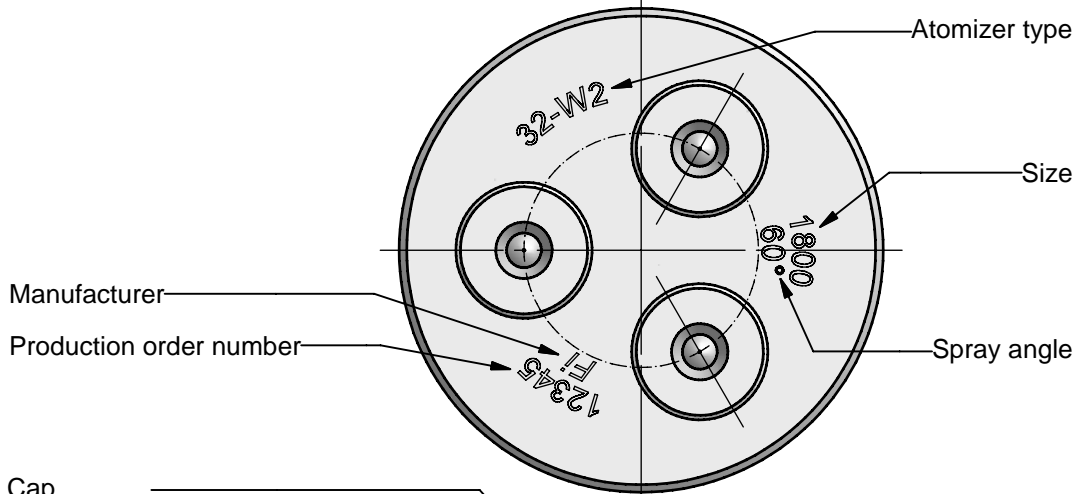

Triplet atomizer
32-W2-"Size"-60°

32-E1L1-4G-E

03-04-2006



Manufacturer
Production order number

Size [kg/h]
60
75
96
120
150
180
210
240
270
300
345
390
435
480
540
600
675
750
825
900
990
1080
1200
1350
1500
1650
1800
1950
2100
2250

Cap
w.st.nr.: 1.4122

Orifice
Type W
w.st.nr.: 1.2510
Tempered 63 Rc

Swirler
Type N
w.st.nr.: 1.2510
Tempered 63 Rc

Self locking nut
w.st.nr.: 1.0715
Zn 6 µm

Circlip
w.st.nr.: 1.4310

Support
w.st.nr.: 1.4122

Needle
w.st.nr.: 1.2767
Tempered 52 Rc

Spring
w.st.nr.: 1707s

Needle holder
w.st.nr.: 1.4122

Retaining washer
w.st.nr.: 1.4122

Supply oil

Return

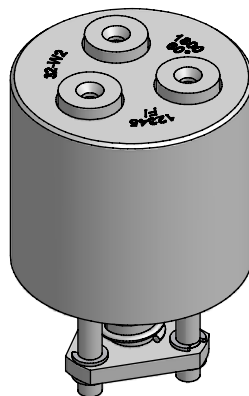

GENERAL DATA:

Test oil viscosity: 5 cSt.
Supply pressure: 25 Bar.

Max. output with closed returnline.

Turn down 1:4 up to 300 at 10 bar return pressure,
over 300 at 8 bar return pressure.

Max. output up to 240 0% +10%
up to 540 0% +7%
over 540 0% +5%

Spray angle: Max. output 60°+5°
Turned down 78°+10°

ORDERING please specify:

- Atomizer type
- Size
- Spray angle
- Quantity