

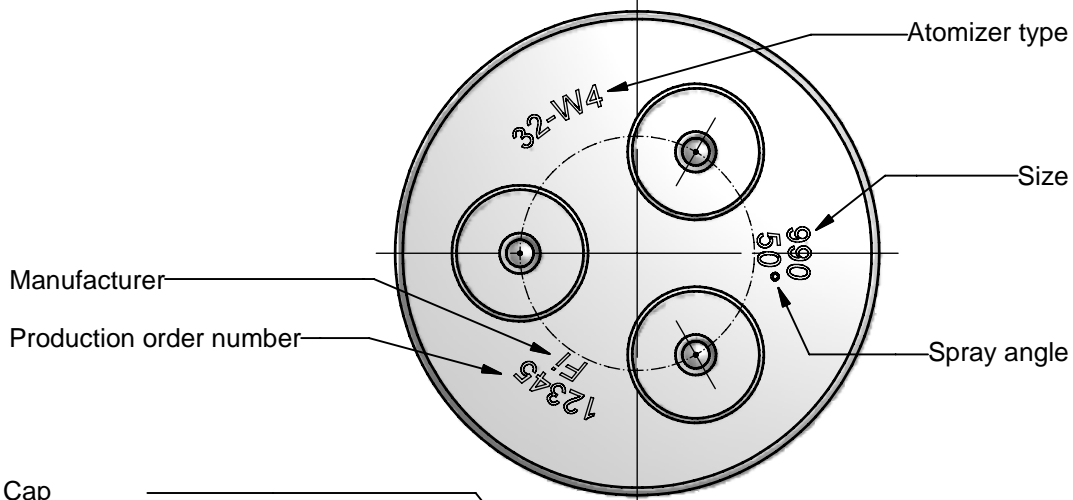

Triplet atomizer  
32-W4-"Size"-50°

32-EBGM-4G-E

11-07-2007



Size [kg/h]
60
75
96
120
150
180
210
240
270
300
345
390
435
480
540
600
675
750
825
900
990
1080
1200
1350
1500
1650
1800
1950
2100
2250

Cap  
w.st.nr.: 1.4122

Orifice  
Type E  
w.st.nr.: 1.2510  
Tempered 63 Rc

Swirler  
Type C  
w.st.nr.: 1.2510  
Tempered 63 Rc

Self locking nut  
w.st.nr.: 1.0715  
Zn 6 µm

Circlip  
w.st.nr.: 1.4310

Support  
w.st.nr.: 1.4122

Needle  
w.st.nr.: 1.2767  
Tempered 52 Rc

Spring  
w.st.nr.: 1707s

Needle holder  
w.st.nr.: 1.4122

Retaining washer  
w.st.nr.: 1.4122

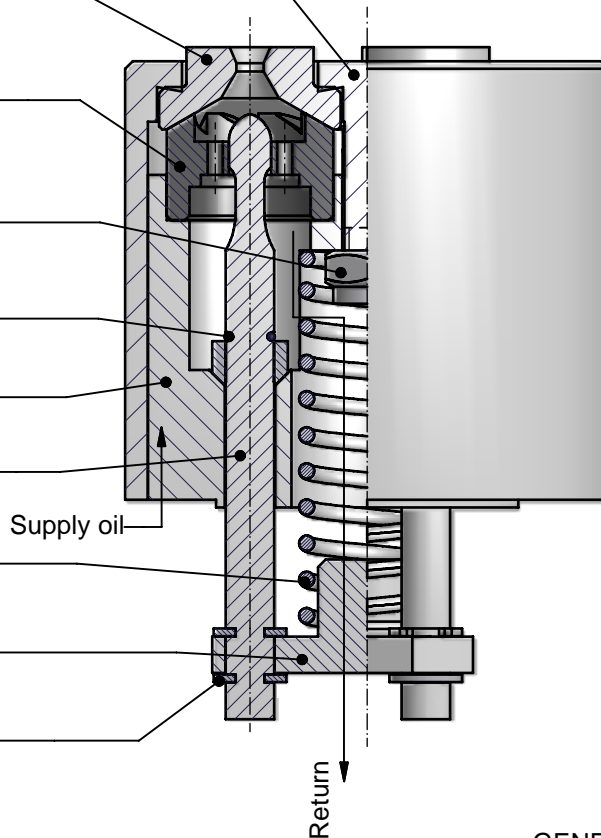

GENERAL DATA:

Test oil viscosity: 5 cSt.  
Supply pressure: 25 Bar.

Max. output with closed returnline.

Turn down 1:4 at 7 bar return pressure,

Max. output	up to 240	0% + 10%
	up to 540	0% + 7%
	over 540	0% + 5%

Spray angle:	Max. output	50°+5°
	Turned down	70°+10°

ORDERING please specify:

- Atomizer type
- Size
- Spray angle
- Quantity

