

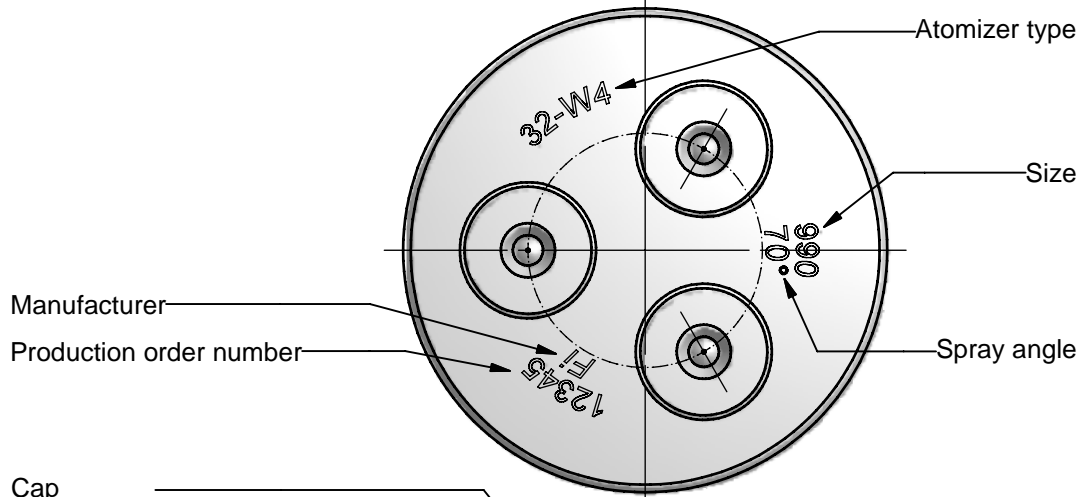

Triplet atomizer
32-W4-"Size"-70°

32-EBPB-4G-E

06-08-2007



Size [kg/h]
75
96
120
150
180
210
240
270
300
345
390
435
480
540
600
675
750
825
900
990
1080
1200
1350
1500
1650
1800

- Cap
w.st.nr.: 1.4122
- Orifice
Type W
w.st.nr.: 1.2510
Tempered 63 Rc
- Swirler
Type C
w.st.nr.: 1.2510
Tempered 63 Rc
- Self locking nut
w.st.nr.: 1.0715
Zn 6 µm
- Circlip
w.st.nr.: 1.4310
- Support
w.st.nr.: 1.4122
- Needle
w.st.nr.: 1.2767
Tempered 52 Rc
- Spring
w.st.nr.: 1707s
- Needle holder
w.st.nr.: 1.4122
- Retaining washer
w.st.nr.: 1.4122

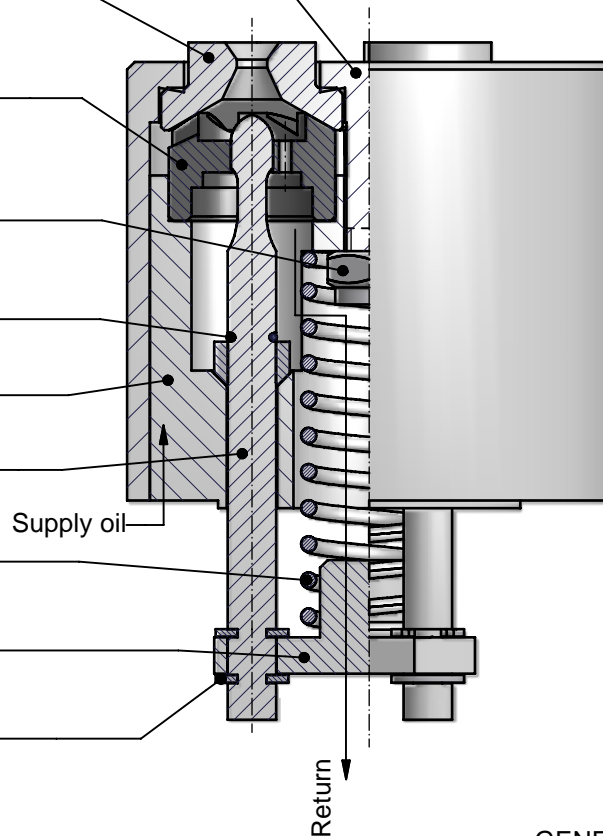

GENERAL DATA:

Test oil viscosity: 5 cSt.
Supply pressure: 25 Bar.

Max. output with closed returnline.

Turn down 1:4 at 7 bar return pressure,

Max. output	up to 240	0% + 10%
	up to 540	0% + 7%
	over 540	0% + 5%

Spray angle:	Max. output	70°+5°
	Turned down	85°+10°

ORDERING please specify:

- Atomizer type
- Size
- Spray angle
- Quantity

